

NEWTONUS PUMP

**END SUCTION CENTRIFUGAL PUMP
EN model**

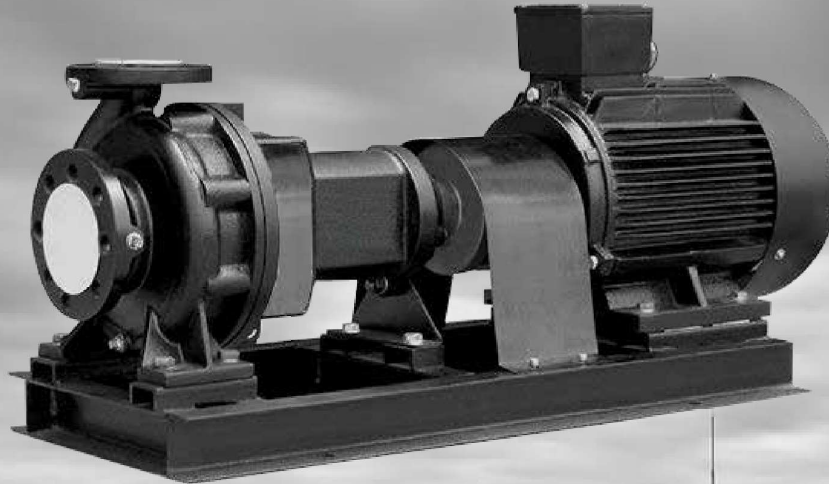

We are professional engineers for energy saving pump & piping

Application :

- Commercial Building (Transfer, booster, fire fighting/hydrant)
- Industrial, power plant (Transfer, booster, fire fighting/hydrant)
- Water Treatment (Transfer, booster)
- Chiller/Air Conditioning, heating (Circulation)
- Agriculture, farming, golf course (Irrigation, sprinkling, circulation)
- Mining (Dewatering, sprinkling)
- Trailer/mobile/pontoon pump (Dewatering, transfer, flood control)
- Sea water desalination (Transfer, booster)

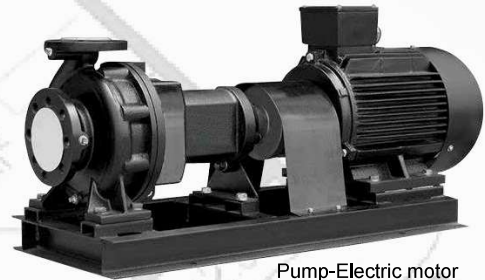

Pump-Electric motor

Specification :

- Maximum flow 900 M3/hour
- Maximum head 170 meter
- Liquid temperatur -15 deg.C to 120 deg.C
- Maximum working pressure 16Bar
- Inlet dia. DN50-DN250 & outlet dia. DN32-DN200
- Liquid pH 6 - 8, clean liquid non grain/fiber, non chemical

Electric motor/ Diesel engine :

- Electric motor 3Ph/380V-660V/50Hz/2Pole or 4Pole
- Diesel Engine 300 rpm to 3000 rpm/12V-24V
- Maximum power : 200 kW

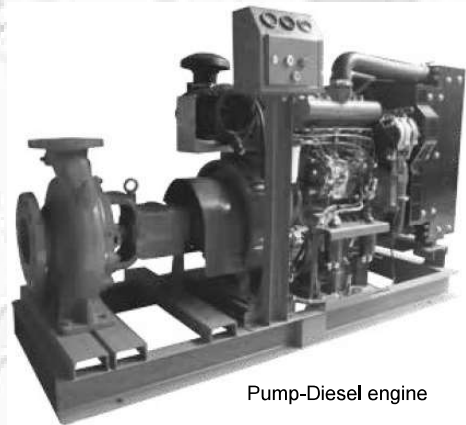

Pump-Diesel engine

Features :

- Back pull out design, so without must disturb pump casing and piping when pump service.
- High quality mechanical seal fitted as standard to all pumps, and gland packing are possible on application
- Installation FCL/tyre coupling with accurate shaft alignment to maintain low noise, highest performance and long life time.

Engineering & pricing solution

The energy saving & long life time of pump is our focus. The pump energy saving is not only determined by pump efficiency, but also depending by pipe diameter, controller, etc. Therefore we are ready to give consultation or training of piping engineering (Free of charge) before purchase the pumps, for as below :

- Calculation to determine the pump flow & total head, pipe diameter & material (inlet/ outlet pipe)
- To avoid cavitation, the suction pipe (negative/positive suction) should be calculated max. suction lift (Hs).
- Selection of pump controller according to the application system
- Selection of pump type according to flow, total head, material and electrical power
- Selection of cheaper price with similar or better pump & application

Konsultasi : WA, BiP 0877 7067 8615, email : engineering@newtonus.com, engineering.newtonus@gmail.com

Performance curve :

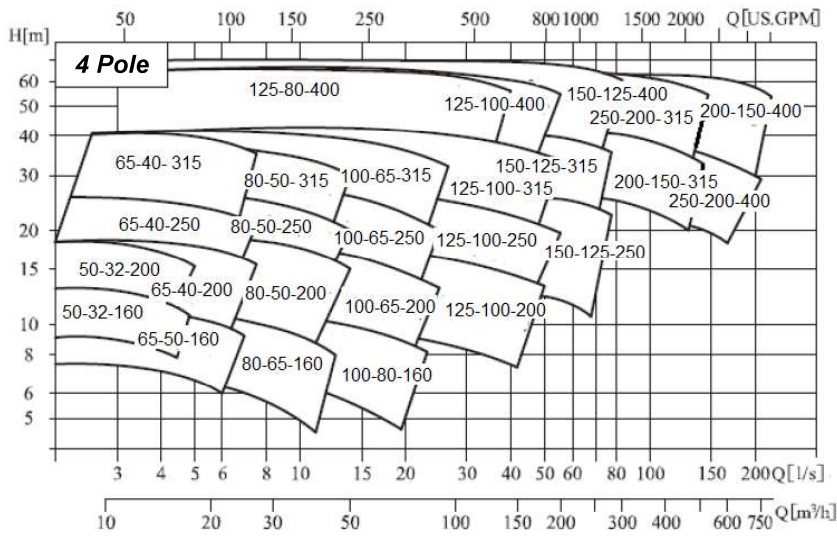
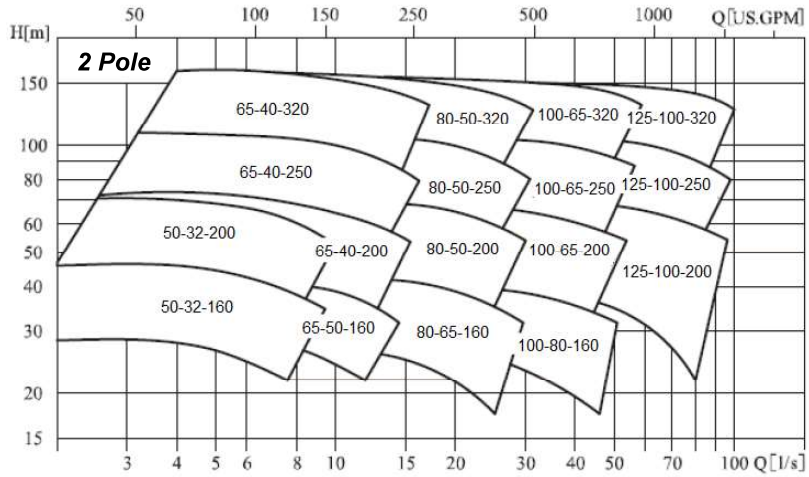

Component & Material :

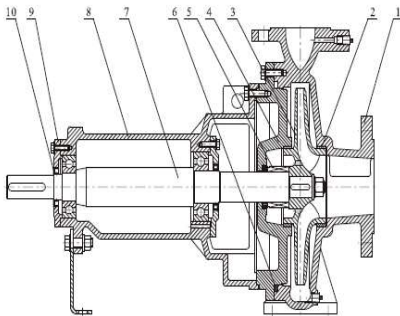

No.	Name	Material
1	Casing	Cast Iron
2	Wear ring	Cast Iron
3	Impeller	Cast Iron /SS 304
4	Casing cover	Cast Iron
5	Mechanical seal	Carbon/Silicon Carbide
6	O ring	NBR
7	Shaft	SS 20Cr13
8	Bearing housing	Cast Iron
9	Bearing cover	Cast Iron
10	Oil seal	NBR

Suction piping installation:

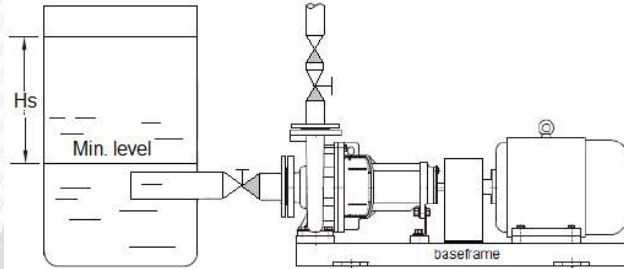

Positive suction, is recommended installation

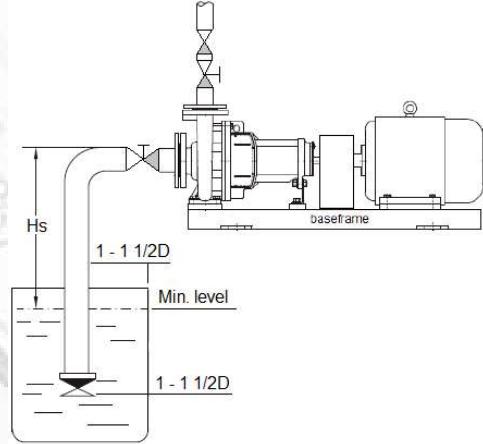

Negative suction. $P > 2.2\text{KW}$, H_s (Max suction lift) should be calculated to avoid cavitation. Recommended $P < 2.2\text{KW}$, $H_s = 1\text{Mtr}-4\text{Mtr}$

Pump installation :

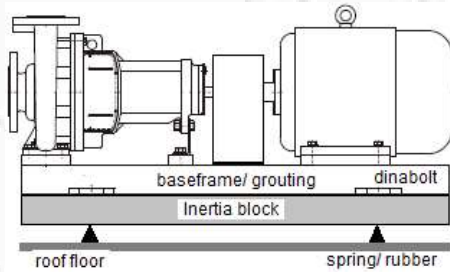

Pump installation, $P > 2.2\text{KW}$ on the roof floor.

To avoid high vibration and noise occurring due to effect of rotation, the pump should be installed inertia block & spring/rubber vibration damper. This installation can avoid the damage of building constructions.

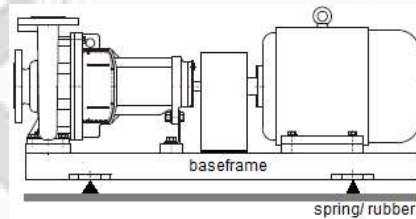

Not recommended pump installation. The base frame will deflection and shaft misalignment.

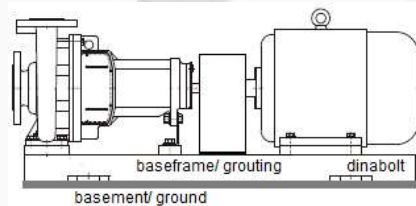

Installation of Pump $> 2.2\text{KW}$ on the ground